

# Air valve( 3/2 way)

## 3A300 Series

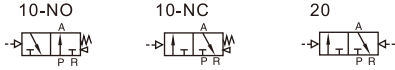

### Symbol



### Product feature

1. Structure in sliding column mode: good tightness and sensitive reaction.
2. Double air control valves have memory function.
3. Internal hole adopts special processing technology which has little attrition friction, low start pressure and long service life.
4. No need to add oil for lubrication.
5. Multi-mounting helps to install and apply.
6. Integrate with the manifold to save installation space.

### Flow chart

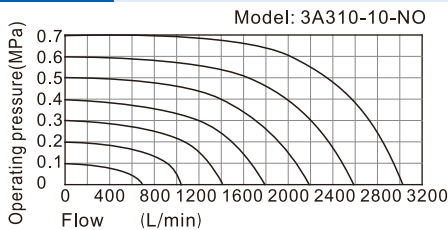

The data in flow rate chart are obtained from AirTAC lab.

### Inner structure

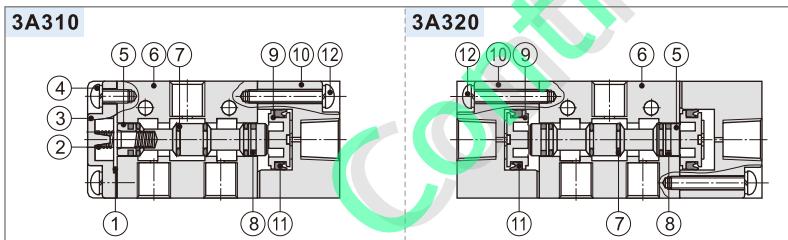

No.	Item	No.	Item	No.	Item
1	Bottom cover gasket	5	Spool	9	Piston
2	Spring	6	Body	10	Pilot body
3	Bottom cover	7	O-ring	11	Piston O-ring
4	Bottom cover screw	8	Wear ring	12	Piston screw

### Specification

Model	3A310-08	3A320-08	3A310-10	3A320-10
Fluid	Air(to be filtered by 40 μm filter element)			
Acting	Exterior control			
Port size [Note1]	In=Out=1/4"		In=Out=3/8"	
Orifice size(Cv)[Note4]	3A310-10,3A320-10:28.0mm <sup>2</sup> (Cv=1.65)			
Valve type	3 port 2 position			
Lubrication [Note2]	Not required			
Operating pressure	0.15~0.8MPa(21~114psi)			
Proof pressure	1.2MPa(175psi)			
Temperature	-20~70°C			
Material of body	Aluminum alloy			
Max. frequency [Note3]	5 cycle/sec			

[Note1] G thread is available.

[Note2] Once lubricated air is used, continue with same medium to optimise valve life span. Lubricants like ISO VG32 or equivalent are recommended.

[Note3] The maximum actuation frequency is in the no-load state.

[Note4] Equivalent orifice S and Cv are all calculated from the flow rate data.

### Ordering code

1 Model	2 Code	3 Valve type	4 Port size	5 Acting type	6 Thread type
3A: Air Valve (3/2 way)	3: 300 Series	10: Single air control 20: Double air control	08: 1/4" 10: 3/8"	NC: Normally close NO: Normally open No this code	G: G Thread

Please refer to 114 for manifold specification and the order way.

### Dimension

#### 3A310

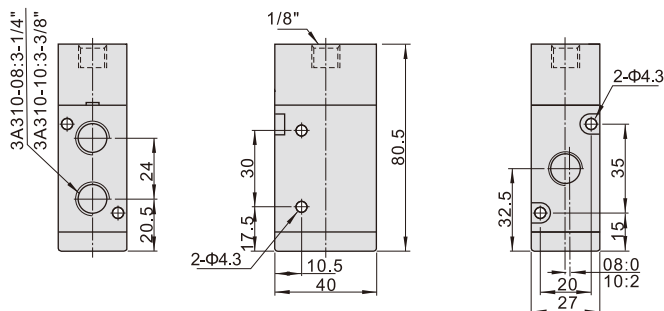

#### 3A320

