



45RM4 FIBER OPTIC FLAME SCANNER MODEL 1001LF

24VDC OPERATION

CE conformity with
EN61000-4-3
EN61000-4-6
EN60730-2-5

IMPORTANT: This bulletin is directed to the licensed boiler service technicians and professional combustion engineers who are experienced in the installation and operation of FIREYE flame safeguard controls. Persons not experienced with Fireeye flame safety products should contact the nearest FIREYE representative, or a qualified service group for assistance.



WARNING: IMPROPER INSTALLATION OF THESE PRODUCTS MAY BE HAZARDOUS TO LIFE AND PROPERTY.

DESCRIPTION

The FIREYE® Type 45RM4LF flame scanner is a self-checking, flame sensing device. It consists of a photodetector and a solid-state, frequency tuned circuit contained in a die-cast aluminum housing. When powered by the 25SU3-2150 amplifier, the scanner detects the presence and absence of flames having certain characteristics.

The 45RM4LF has a 16-position rotary selector to select the ideal flame “flicker” frequency. This is effective in detecting and discriminating Flame ON and Flame OFF conditions on installations where low frequency emissions predominate (pulverized coal.). This allows the 45RM4LF scanner to discriminate between the targeted flame and background flame for a wide range of applications.

The 45RM4LF scanner incorporates a large area lead sulfide cell to detect a wide variation of background brightness without cell washout. An integral 10 segment Flame LED bargraph is provided to assist in the installation and sighting of the scanner.

The scanner uses an “electronic shutter” assembly to replace the electro-mechanical shutter. A shutter pulse from the flame amplifier is still required to activate the shutter.

The scanner is powered by 24VDC provided from an external power supply or by the 25SU3-2150 amplifier. 24VDC operation reduces electrical noise frequencies resulting from 120VAC operation (e.g. 60HZ, 120HZ. etc.). A quick disconnect has also been incorporated into the scanner to provide ease of installation and removal.

NOTE: The 45RM4-1001LF Flame Scanner is specifically designed for use with the 25SU3-2150 amplifier on COAL FIRED applications



APPLICATION

When properly sighted, the 45RM4LF scanner can discriminate the target flame from adjacent flames and/or background radiation. These unique design features enable the scanners to be applied, in conjunction with a compatible Fireeye flame safeguard control, on single and multiple burner fired apparatus including power, industrial process and electric utility furnaces and boilers, to provide flame failure protection.



WARNING: The response of the scanner depends on burner configuration as well as on the turbulence and spectral characteristics of the flames. Application assistance is available on request.

OPERATION

Type 45RM4LF Scanner uses the modulation occurring within a flame that is produced by wave lengths in the visible and near infra-red range. The scanner discriminates between the targeted burner and the background (e.g.: a fireball or flame from other burners, etc.) by observing the amount of signal resulting from the band pass filter in the scanner. The target burner will also have more signal at the selected frequency than the background. The 16 position rotary switch allows the band pass filter to be selected to the appropriate frequency for the application. Many lo-nox applications and lazy fires have the highest signal differential at the lower frequency settings (e.g. 10-100 Hz).

The detector board of the scanner consists of a current to voltage convertor with a feedback loop to maintain the DC voltage output at its maximum. This DC voltage is a function of the background brightness. By holding this DC voltage at its maximum, the maximum AC flame signal is achieved.

This AC signal is then applied to a switched capacitor digital filter. The filter is configured as a band-pass amplifier whose center frequency is dependent on the 16 position rotary switch.

The output of this filter is then connected to a full wave rectifier. The output of the rectifier is used to illuminate the Flame LED bargraph, as well as feed the power supply/output board which processes the signal for transmission to the 25SU3-2150 amplifier. The LED can be used to indicate sufficient signal to energize the flame relay at the flame amplifier. This Flame LED bargraph assists in aligning the scanner to the flame being scanned.

Also included in the scanner is an "electronic shutter" assembly that permits the self-checking circuit within the associated Fireeye control to verify that the scanner and signal circuits are operating properly in the absence of flame signal. The scanner provides pulses to the flame amplifier during shutter open intervals. During shutter close intervals, the cell is disabled, and the scanner pulses should be interrupted. The flame amplifier expects to see no pulses during the shutter closed interval and will shut down (de-energize the flame relay) if it does.

The 45RM4LF scanner is compatible with the 25SU3-2150 amplifier.

FIGURE 1. TYPE 45RM4LF SCANNER DIMENSIONS

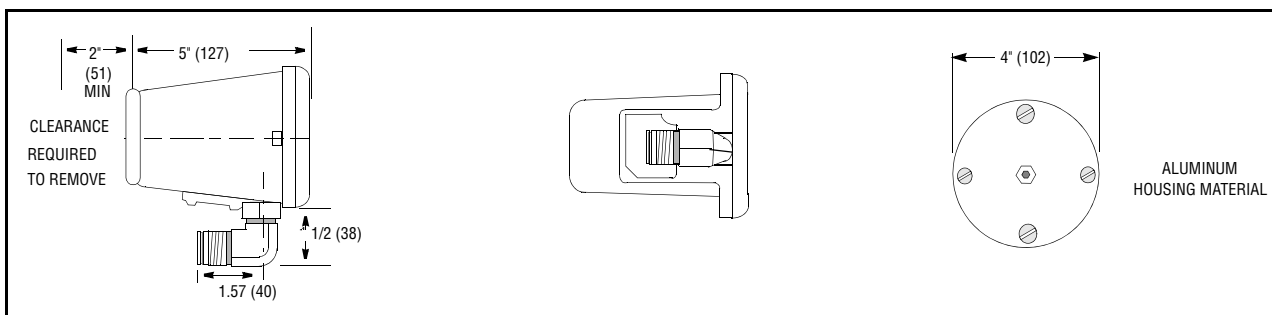



SPECIFICATIONS

Mounting: The 45RM4LF Scanner is connected to the Fireye Fiber Optic inner assembly by and where the two screws are located.

Heat Insulating Nipple 1" NPT or 1" BSP

Housing Material: Die Cast Aluminum

Weight: 2.4 Lbs. (1.1 kg)

Electrical

Power Requirements: 24VDC from the 25SU3-2150 amplifier or 24VDC (+ 10%, -15%) from an external power supply. Current rating 100 mA per scanner.

Connection: Quick Disconnect.

Frequency Adjustment: Turn the 16 position rotary switch located under the cover on the rear of the scanner housing with a small screwdriver to the appropriate frequency.

Temperature Range

Maximum Operating: 150°F (65°C)

Minimum Operating: -13° F (-25°C)

Humidity: 0% to 95% R.H. Noncondensing.

Purge Air Flow Required

Source: Clean Ambient

Volume Required: 4.0 SCFM (113L/min) at $\frac{3}{8}$ inch threaded housing inlet or 1 inch "Y" fitting in scanner sight pipe. Temperature near the upper limit of the scanner operating range and/or use with dirty fuels may require up to 15 SCFM (425L/min).

Specifications subject to change without notice.

Electrical Accessories: Fireye scanner cable P/N 59-470 is used for wiring connections between the scanner(s) and the control terminals. Each wire is color coded for connection as follows:

- BLACK is used for the +24VDC terminal.
- REDis used for the self check terminal.
- WHITE is used for the 24VDC common terminal.
- GREEN is flame signal terminal.
- BLUE unused.
- YELLOW unused.

ALIGNMENT AND ADJUSTMENTS

Before installing or adjusting scanners, flame scanning objectives and boiler/furnace operation should be thoroughly reviewed.

The following procedures are recommended to ensure optimum flame detection and discrimination. Flame discrimination is the ability to see only one burner or one ignitor with other burners or ignitors operation nearby.



CAUTION: These procedures should be used whenever parts are replaced, when the scanner has been moved, when the flame shape is altered (additional fuels, new burners, burner/register modifications), as well as on new installations.



DESCRIPTION OF FEATURES

The Type 45RM4LF, Model 1001 Flame Scanner has the following significant features to improve flame discrimination.

- Gain adjustment potentiometer.
- Selector switch to enable or disable Background Gain Control Function.
- Set of 10 LED indicator lights to show flame signal strength.
- 16 Position frequency selector switch.

Gain Adjustment Potentiometer

The adjustment potentiometer is located under the rear panel of the scanner between the 16 position frequency selector switch and the Background Gain Control selector switch. The gain adjustment potentiometer is used to properly amplify both flame on and flame off signals so that maximum discrimination can be attained.

The potentiometer has four (4) active turns and “free-wheels” at either end of travel.

LED Indicator Lights (Flame Strength)

The 45RM4LF is equipped with a set of 10 LED's to indicate flame strength. These LED's are helpful in scanner sighting as well as in scanner setup. The LED's are linear, with each LED representing approximately 75 output pulses per second (when viewed at a 25SU3-2150 amplifier).

Background Gain Control (BGC) Selection

Background Gain Control (BGC) inversely adjusts the flame signal gain based on flame brightness as sighted by the scanner. (e.g.: flame brightness increases, automatic gain is decreased, and flame signal is decreased).

On some burners, the flame brightness (as sighted by the scanner) increases when the monitored flame goes out due to background refractory, adjacent flames, etc. On these types of burners, the BGC would be selected ON so when the monitored flame goes out, the brightness increases, the gain would be automatically decreased, the strength of the flame signal is decreased, and the flame amplifier would drop out the flame relay. On other burners the opposite is true, and BGC would be selected OFF.

16 Position Frequency Selector Switch

The 45RM4LF Scanner is equipped with a 16 position frequency selector switch to aid in the detection and discrimination of the Flame-On and Flame-Off conditions. Depending on the nature of the fuel being burned and the operation of the burner, the modulation frequencies of the flame for these two conditions will vary. The frequency selector switch allows the user to select the appropriate frequency where the greatest discrimination between the Flame-On and Flame-Off condition exists. The selector switch is a rotary switch and has a range for 9 Hz (Position 0) to 76.5 Hz (Position F). The adjustment from the lower to higher frequencies is linear. See below. The 16 position rotary switch is located under the rear cover of the scanner.

SWITCH POSITION	0	1	2	3	4	5	6	7	8	9	A	B	C	D	E	F
FREQUENCY (Hz) 1001LF	9	13.5	18	22.5	27	31.5	36	40.5	45	49.5	54	58.5	63	67.5	72	76.5

LOCATION OF 45RM4LF ADJUSTMENTS (Electrical Connector Facing Downward)

BACKGROUND GAIN CONTROL SWITCH

ON
OFF

LED INDICATOR LIGHTS

16 POSITION FREQUENCY SELECTOR SWITCH

GAIN ADJUSTMENT POTENTIOMETER

Rear cover removed, showing 16 position frequency selector switch and LED indicator lights, and background gain control switch.

45RM4LF BANDPASS FILTER RESPONSE

SWITCH POSITION

0 = 9Hz 3 = 22.5Hz 6 = 36Hz A = 56Hz D = 67Hz

FREQUENCY (Hz)

45RM4LF SCANNER SET-UP PROCEDURE

Frequency and Gain Selection Procedure

The following steps are offered as a guide in setting up the scanner on a multi-burner application where background sources of infrared radiation may be present. The goal is to set the flame “flicker” frequency and scanner “gain” that yields the greatest flame ON:OFF signal ratio. For purposes of illustration only, frequency switch position “6” was selected as the starting point.

1. Select a mid-point HZ (e.g., “6”) and “gain” at maximum.
2. With background burners firing, turn ON target burner.
3. Readjust “gain” to yield 6-8 LED’s at the 45RM4LF.
4. Adjust scanner alignment to maximize LED’s.
5. Sweep through all 16 HZ positions, recording LED’s at each step.
6. Turn target burner OFF.
7. Sweep all 16 HZ positions, recording LED’s at each step.
8. Select HZ with the greatest flame ON:OFF ratio.

EXAMPLE: FLAME SIGNAL LEDS

FREQUENCY SWITCH POSITION	0	1	2	3	4	5	6	7	8	9	A	B	C	D	E	F
LEDS WITH FLAME ON	10	10	9	8	8	7	6	6	5	3	1	1	1	0	0	0
LEDS WITH FLAME OFF (BACKGROUND)	10	10	8	7	5	3	2	2	2	2	0	0	0	0	0	0
ON/OFF RATIO	1.0	1.0	1.1	1.1	1.6	2.3	3.0	3.0	2.5	1.5	—	—	—	—	—	—



In the above example, frequency switch positions A, B, and C yielded the highest ratio, but only a marginal flame ON signal. Instead, switch positions 6 or 7 would be selected as they yielded a very good ON / OFF flame signal ratio and a strong flame ON signal.



Background Gain Control (BGC) Switch Position Selection Procedure

1. Place BGC switch OFF (toward cable connector).
2. With target and background burners firing at high input, record flame LED's at the 45RM4LF.
3. Turn target burner OFF, record flame LED's and determine flame ON:OFF ratio.
4. Place BGC switch ON (away from cable connector).
5. Turn target burner ON, record flame LED's.
6. Turn target burner OFF, record flame LED's and determine flame ON:OFF ratio.
7. Select the BGC switch position that yielded the greater flame ON:OFF LED ratio, and /or yielded the greater LED stability.

AMPLIFIER ADJUSTMENT

Digital Controls (25SU3-2150)

The digital controls have adjustable flame relay pull-in and drop-out thresholds, in terms of the scanner output pulses viewed on the digital control's display. Assume, for example, the 45RM4LF scanner generated 600 pulses per second (pps) when the target flame was ON, and 200 pps when the target flame was OFF (due to background flames). You would program the digital control's "Flame Relay ON Threshold" to some value lower than 600 pps, and program the "Flame Relay OFF Threshold" to some value higher than 200 pps. Alternately, you may reduce the scanner's "gain" setting to yield 300 pps (ON) and 0 pps (OFF). Verify the actual pulse counts (flame ON and flame OFF) at all firing conditions to confirm that the programmed thresholds provide reliable detection and discrimination at all times. See "CAUTION" below.



CAUTION: On all applications the scanner and amplifier must be tested by starting and stopping the burner several times to ensure proper operation. (e.g.: The flame relay must reliably drop out for all flame out conditions.) This testing should be done with various adjacent burners on and off and at various load levels. This is a requirement for proper operation.

SCANNER WIRING

All wiring to the scanner should be rated at 600 volts and 90C. For runs less than 1000 feet, the use of Fireeye Scanner Cable (4-18 AWG, 2-22AWG, overall shield), P/N 59-470 is recommended. Consult the factory for runs in excess of 1000 feet.

The scanner cable should be routed to the quick disconnect using acceptable wiring practices (e.g. use of wiring troughs—keep scanner cable away from wiring for high inductive loads, etc.).

QUICK DISCONNECT KIT P/N 129-127-6 (ordered separately)

For ease of installation and removal, a quick disconnect is used with the 45RM4LF scanners. The male connector is factory mounted on the scanner. The female cable connector kit, P/N 129-127-6, is ordered separately. This assembly procedure applies to Fireeye six-conductor cable (P/N 59-470), eight-conductor cables (P/N 59-471), and obsolete four-conductor cable (P/N 59-221).

The connector kit contains both a cord-grip strain relief fitting, and an adapter for use with 1/2" flexible conduit. The installer must select either one style fitting or the other.

Locate the end of the cable where the red wire is *clockwise* with respect to the white wire. For ease of assembly, this end should be connected to the scanner quick disconnect.

ASSEMBLY (Refer to figure 4)

1. Before stripping cable jacket, test the rubber cable seal for proper fit, (part of cable seal kit). Depending on the cable used, it may be necessary to remove inner ring(s) to provide a snug fit. Set aside until step 8.
2. Strip the outer cable jacket 2 1/2 inch (64 mm).
3. Trim insulated conductors to 1 3/8 inch (35 mm), leave the shield drain wire 2 1/2 inch.
4. Strip individual conductor insulation 5/16 inch (8 mm).

5. Select either the Option #1 or the Option #2 fittings (see figure 4).
Option #1: Slide the cord-grip strain relief fitting onto the scanner cable. (The fitting contains an internal bushing suitable for Fireye six-conductor cable, P/N 59-470. If Fireye eight-conductor cable is used, P/N 59-471, use the larger bushing provided in the kit).
Option #2: Slide the PG16 to 1/2" Flexible Conduit Adapter and the PG11/PG16 thread adapter onto the scanner cable.
6. From the cable seal kit, install the first of two flat washers onto the cable.
7. Fold the shield drain wire back along the cable outer jacket.
8. From the cable seal kit, slide the rubber seal and second flat washer, (part of cable seal kit), onto the cable *over* the shield drain wire. Leave the rubber seal on top of the *end* of the drain wire until step 15. Discard the nut from the cable seal kit.
9. Solder the female contacts onto the individual conductors, (use the *least* amount of solder). Install the smaller female contacts on the smaller 22 AWG scanner wires (blue, yellow, brown, orange) if used.
10. Install the connector hood on the cable, making sure the hood nut is removed.
11. Install the contacts into the female insert in the appropriate order. When properly installed, the contacts will "click" into the insert. Verify by pulling slightly on each wire.
12. Place the threaded hood nut over the female insert.
13. Slide the connector hood over the female insert, aligning the hood locating "key" with the wide groove on the female insert.
14. Tighten the threaded hood nut.
15. Slide the second flat washer and the rubber seal into the connector hood. Push into place until firmly seated.
16. Wrap the shield drain wire around the cable jacket *one* turn only, (between the rubber seal and the first washer, wrapped *clockwise* as viewed from the conduit or strain relief adapter), and trim any excess length.
17. Slide the first flat washer into the connector hood, on top of the drain wire.
18. Thread either the Option 1 or Option 2 fittings and tighten firmly to properly compress the rubber seal. This also compresses the first washer against the drain wire, electrically connecting the shield to the connector hood. Torque to 35 inch pounds.

Before applying power, perform a continuity check on each conductor to confirm proper assembly. Confirm that you have continuity between the cable shield (at the amplifier end of the cable) and the quick disconnect hood (metal housing).

FIGURE 2.

QUICK DISCONNECT TERMINALS

	WIRE COLOR	PIN	FUNCTION
59-470	GREEN	→ 3	FLAME SIGNAL
	RED	→ 2	SHUTTER
	WHITE	→ \perp	COMMON
LEADS	BLACK	→ 1	+24VDC
	BLUE	→ 5	(UNUSED)
	YELLOW	→ 7	(UNUSED)

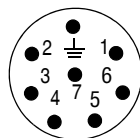

FIGURE 3.

FOR EASE OF CONNECTOR ASSEMBLY, INSTALL ON END SHOWN

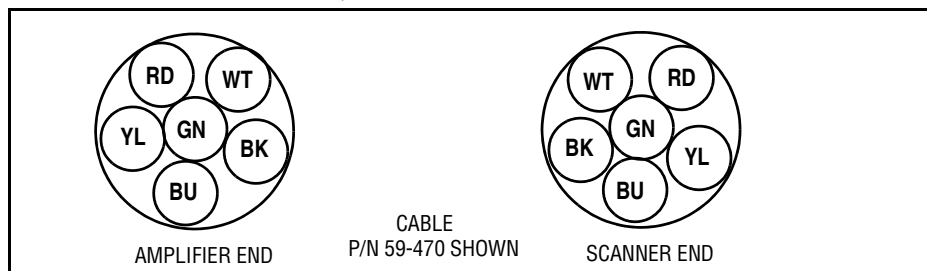
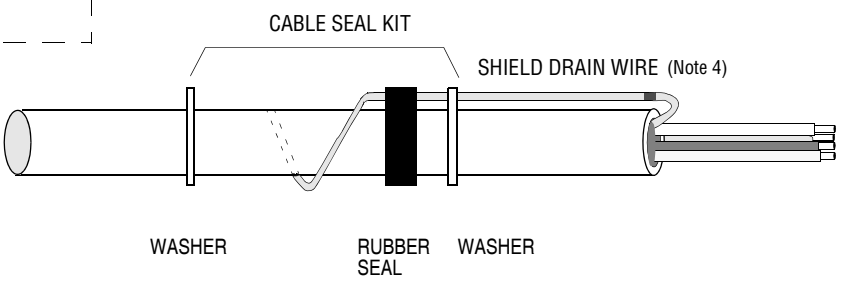
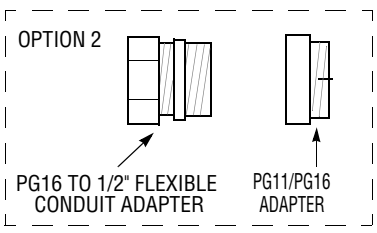
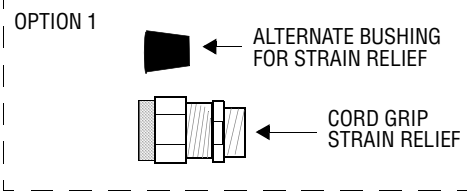
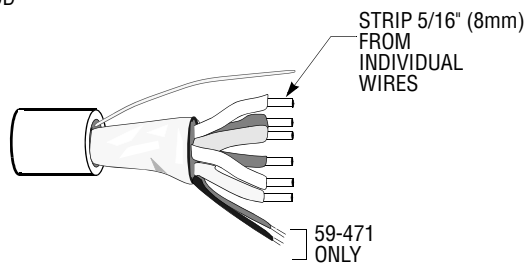
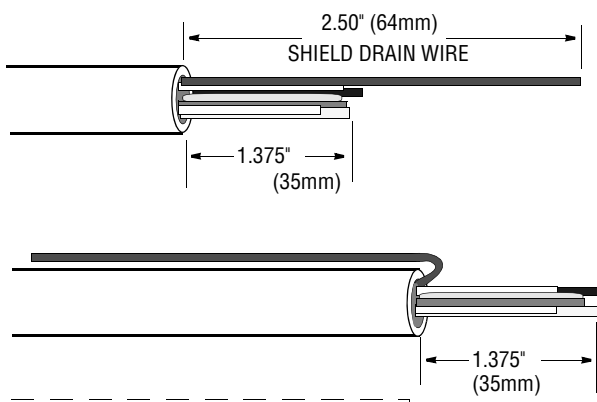
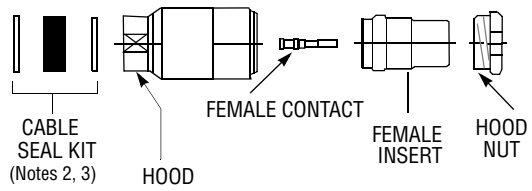
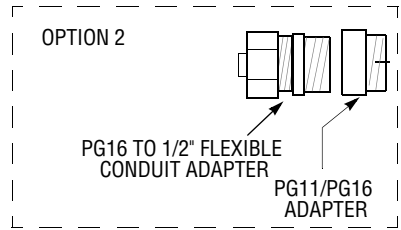
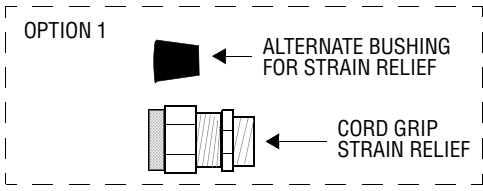

FIGURE 4. FEMALE CABLE CONNECTOR ASSEMBLY DETAIL

(Note 1)
(Note 5)



- NOTE 1: SELECT EITHER OPTION 1 OR OPTION 2 FITTINGS.
- NOTE 2: THE NUT FROM THE CABLE SEAL KIT IS NOT USED.
- NOTE 3: REMOVE INNER RING(S) FROM RUBBER SEAL FOR PROPER FIT ONTO CABLE.
- NOTE 4: WRAP DRAIN WIRE 1 TURN CLOCKWISE AROUND CABLE JACKET.
- NOTE 5: OPTION #1: THE CORD GRIP STRAIN RELIEF CONTAINS A BUSHING SUITABLE FOR FIREYE 59-470 CABLE (0.375" - 0.438" O.D.). IF FIREYE 59-471 CABLE IS USED, SUBSTITUTE THE ALTERNATE BUSHING (0.500" - 0.562" O.D.). TORQUE TO 35 INCH POUNDS.

GROUNDING AND SHIELDING TECHNIQUES

FOR USE ON SCANNERS OR SCANNER CABLE LOCATED WITHIN 12" OF A HIGH ENERGY OR HIGH VOLTAGE SOURCE.

1. The scanner and scanner cable (preferably within flexible conduit) MUST be located at least one foot (1') from the ignition source.
2. Run a ground wire from the ignition transformer chassis to the ignitor assembly.
3. Replace all frayed, cracked, or dirty (oily) ignition wire. Ignition wire must be in good working condition.
4. Electrically isolate the scanner from the burner using a heat insulating nipple provided with the scanner, (P/N 35-127-1 or 35-127-3).

NOTE: If purge air is required, PURGE AIR must be electrically isolated from the scanner (e.g. isolated short rubber hose).

Notes for 45RM4LF scanners:

1. Connect the scanner cable's shield to terminal C at the control end.
2. Connect the scanner cable's shield to the quick-disconnect housing at the scanner end. This connection is done at the factory on preassembled cables, e.g. P/N 59-470-010.

FIGURE 5. WIRING COMBINATIONS TO 60-2478 CONNECTOR, USED WITH CARD RACK FOR 25SU3-2150 FLAME AMPLIFIERS

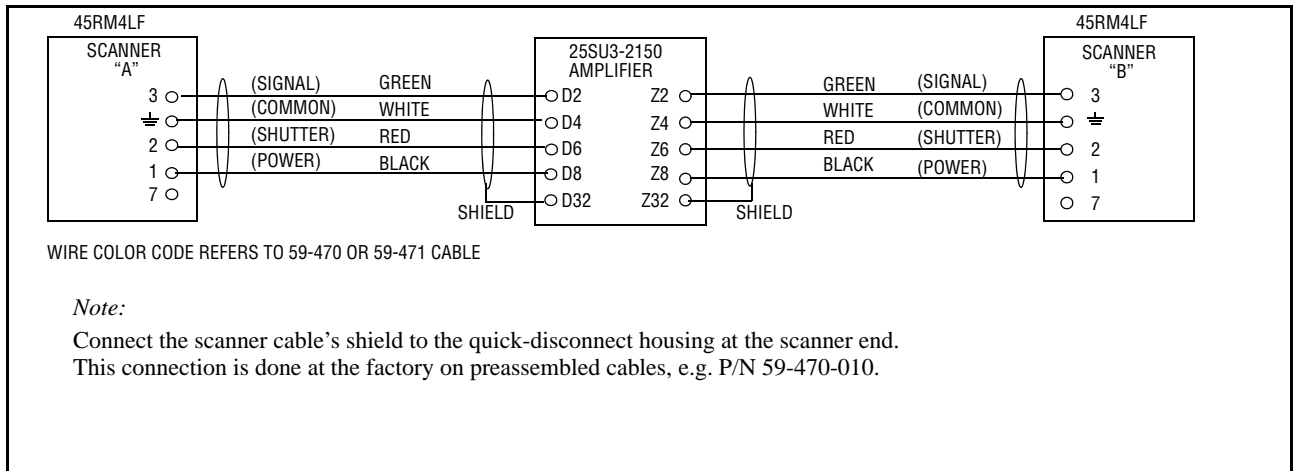

MAINTENANCE

Humidity Effects: It is considered good practice to minimize any possible adverse effects of high humidity by keeping electronic equipment continuously powered, even during periods when it is not in use.

Scanner: If continuous air purging of the scanner sight pipe is not completely effective in preventing viewing window contamination, a schedule should be set up for periodically cleaning the window. Always use a soft clean, (non-oily) cloth to wipe the window. For maximum assurance that oily films will be removed, wash first using a cloth dampened, (not dripping) with a concentrated detergent solution.

Use original Fireeye repair parts to maintain optimum operation.



CAUTION: DISCONNECT OR SHUT OFF ELECTRIC POWER WHEN WORKING ON SCANNER.

TROUBLESHOOTING

The following steps should be performed if flame is not detected:

1. Check scanner wiring for breaks, loose, or improper connections.



WARNING: PROTECTIVE FILTERED LENSES SHOULD BE WORN WHEN VIEWING FLAME. INFRARED AND ULTRAVIOLET ENERGY CAN BE DAMAGING TO THE EYES.

2. Look down the sight pipe.
 - a. Scanner should have an unrestricted view for all firing conditions.
 - b. The flame's primary combustion zone (first 1/3 of flame) should be within the scanner's field of view for all firing loads.
3. Check to see if the self-check circuits are operating. There should be 16-24 VDC (cycling) between self-check and common terminals (refer to amplifier bulletin).
4. Measure voltage across scanner terminals:
 - a. Between signal and common terminals there should be 12 VAC pulses of 40 microseconds.
 - b. Between power and common terminals there should be +24 VDC.
5. Scanner operation can be checked by aiming it at a fluorescent, or high intensity light and waving your hand in front of the scanner's lens. The meter of the associated control should indicate flame.
6. Check to see that an external selector switch is connected to the associated Fireeye control's sensitivity (threshold) select terminals.
7. Reposition scanner so it is properly aligned for best flame signal.





NOTICE

When Fireeye products are combined with equipment manufactured by others and/or integrated into systems designed or manufactured by others, the Fireeye warranty, as stated in its General Terms and Conditions of Sale, pertains only to the Fireeye products and not to any other equipment or to the combined system or its overall performance.

WARRANTIES

FIREEYE guarantees for *one year from the date of installation or 18 months from date of manufacture* of its products to replace, or, at its option, to repair any product or part thereof (except lamps, electronic tubes and photocells) which is found defective in material or workmanship or which otherwise fails to conform to the description of the product on the face of its sales order. **THE FOREGOING IS IN LIEU OF ALL OTHER WARRANTIES AND FIREEYE MAKES NO WARRANTY OF MERCHANTABILITY OR ANY OTHER WARRANTY, EXPRESS OR IMPLIED.** Except as specifically stated in these general terms and conditions of sale, remedies with respect to any product or part number manufactured or sold by Fireeye shall be limited exclusively to the right to replacement or repair as above provided. In no event shall Fireeye be liable for consequential or special damages of any nature that may arise in connection with such product or part.



FIREEYE
3 Manchester Road
Derry, New Hampshire 03038 USA
www.fireeye.com

CU-31LF
APRIL 12, 2013
supersedes December 12, 2005